



- High Accuracy
- Broad Bandwidth
- Low Zero-drift

Shenzhen Hangzhi Precision Electronics Co., Ltd.

Product Model: AIT1500-D50
Measurement Range: DC \pm 1500A
Accuracy: 50PPM

AIT1500-D50 High-Precision Current Transducer

AIT1500-D50 has a high gain and measurement accuracy in the full bandwidth range, due to the application of the multi-point zero-flux technology system and high-frequency ripple sensing channel on top of currently existing DC sensor technology.

The multi-point zero-flux technology system secures the high accuracy by utilizing the technology combination of exciting magnetic flux closed-loop control, self-excited magnetic flux gate and multi-closed-loop control that realizes the closed-loop control between excitation magnetic flux and AC/DC magnetic flux generated by primary current, while the high-frequency ripple sensing channel allows the sensor to have the high performance over the full bandwidth range.

Product photo





- High Accuracy
- Broad Bandwidth
- Low Zero-drift

Shenzhen Hangzhi Precision Electronics Co., Ltd.

Product Model: AIT1500-D50
Measurement Range: DC±1500A
Accuracy: 50PPM

Key Technologies

- ◇ Excitation closed-loop control technology
- ◇ Self-excitation demagnetization technology
- ◇ Multi-point zero-flux technology
- ◇ Temperature control compensation technology
- ◇ Multi-range automatic switching technology

Features

- ◇ Insulated measurement between primary and secondary side
- ◇ Excellent linearity and accuracy
- ◇ Extremely low temperature drift
- ◇ Extremely low zero drift
- ◇ Broad band and low response time
- ◇ Strong anti-electromagnetic interference

Application Domain

- ◇ Medical Equipment: Scanner, MRI
- ◇ Power Industry: Converter, Inverter
- ◇ Renewable Energy: Photovoltaic, Wind energy
- ◇ Testing Instrument: Power analyzer, High-precision power supply
- ◇ Smart Power Grid: Power generation and battery monitoring, Medium low voltage substation
- ◇ Industry Control: Industrial motor drive, UPS, Welding, Robot, Hoist, Elevator, Ski lift
- ◇ Rail Transit: EMU, Metro, Trolley car
- ◇ Ship: Electric driven ship
- ◇ Car: Electric car

Electrical Performance

Parameter	Symbol	Measuring Conditions	Min	Typ	Max	Unit
Primary nominal direct current	I _{PN_DC}	—	—	±1500	1650	Adc
Primary nominal RMS current*	I _{PN_AC}	—	—	1060	1167	Aac
Power supply voltage AC	U _C	—	—	220	—	Vac
Current consumption	I _C	Rated primary current	—	—	210	mA
Conversion ratio	K _N	Primary/secondary	—	1500:1	—	—
Secondary nominal RMS current	I _{SN}	Rated Primary current	—	±1.0	—	A
Secondary burden resistance	R _M		0	1	2	Ω

* refers to AC effective value



- High Accuracy
- Broad Bandwidth
- Low Zero-drift

Shenzhen Hangzhi Precision Electronics Co., Ltd.

Product Model: AIT1500-D50
Measurement Range: DC±1500A
Accuracy: 50PPM

Accuracy Measurement

Parameter	Symbol	Measuring Conditions	Min	Typ	Max	Unit
Accuracy	X_G	Input direct current, 25±20°C	—	—	50	ppm
Linearity error	ϵ_L	—	—	—	20	ppm
Offset temperature coefficient	T_C	—	—	—	0.1	ppm/K
Offset stability over time	T_T	—	—	—	0.2	ppm/month
Power supply interference	T_V	—	—	—	1	ppm/V
Zero offset current	I_0	@25°C	—	—	1 (can be adjusted to zero by users)	ppm
Ripple current	I_N	DC-10Hz	—	—	0.5	ppm
Step response time to 90% I_{PN_DC}	t_r	di/dt of 100A/μs	—	—	1	μs
di/dt accurately followed	di/dt	—	100	—	—	A/μs
Frequency bandwidth (-3dB)	BW	—	0	—	300	kHz
Zero offset current	I_{OT}	Full temperature range	—	—	±5	μA

Safety Characteristics

Parameter	Symbol	Measuring Conditions	Value	Unit
Insulation voltage / Between primary and secondary	Ud	50Hz, 1min	5	KV
Impulse withstand voltage / Between primary and secondary	Uw	50μs	10	KV
Creepage distance / Between primary and shield	d _{CP}	—	11	mm
Clearance distance / Between primary and shield	d _{CI}	—	11	mm
Comparative tracking index	CTI	IEC-60112	600	V

General Characteristics

Parameter	Symbol	Measuring Condition	Min	Typ	Max	Unit
Ambient operating temperature	T_A	—	-40	—	+85	°C
Ambient storage temperature	T_S	—	-40	—	+85	°C
Relative humidity	RH	—	20	—	80	%
Mass	M	—	—	8.5±1	—	Kg



- High Accuracy
- Broad Bandwidth
- Low Zero-drift

Shenzhen Hangzhi Precision Electronics Co., Ltd.

Product Model: AIT1500-D50
Measurement Range: DC \pm 1500A
Accuracy: 50PPM

Safety



Cautions

This specifications documents provide users with relevant precautions for installation, commissioning, operation and maintenance. Please read carefully before installation and use. This manual is provided with the product, please keep it in a proper place for reference during maintenance.

The device must be used according to the manufacturer specifications, otherwise there are risks to damage the device, other equipment connected, and safety risks to operators.

Always inspect the device and its accessories, and confirm they are in good status before energize the device.

If you find any damage to the device housing, fixing, power cord, connecting cables, or connected equipment, immediately disconnect the device from the power source.

If you have concerns about the safe operation of the equipment, you should immediately shut down the equipment and the corresponding accessories, and get in touch with the technical support department of our company as soon as possible to communicate and solve the problem.



Danger

The current sensor is not allowed to be used when the secondary output is open-circuited, that is, when the primary has current or the sensor is powered on, the secondary output terminal is not allowed to be disconnected; only when the bus has no current and the sensor is not powered on, the current output terminal of the sensor can be disconnected . Otherwise, high voltage may be induced and there is a danger of electric shock or equipment damage.

When you need to move the product, please be sure to cut off the power first and unplug all the connecting cables connected to it.



- High Accuracy
- Broad Bandwidth
- Low Zero-drift

Shenzhen Hangzhi Precision Electronics Co., Ltd.

Product Model: AIT1500-D50
Measurement Range: DC ± 1500A
Accuracy: 50PPM

Operating Status Instructions

◇ Normal status:

The green indicator is on when the device is running normally.

◇ Fault status:

The green light will be off when the transducer is in fault mode.

Trouble-shooting:

a) When the green light is off, the power supply should be checked as the first step;

b) If the power supply is normal, then the primary current is over the specified measurement range and the transducers will be in overload mode.

In this mode, the transducers will be working in non-zero flux mode, that the secondary current remains at specified maximum output, the secondary and primary currents are not in proportional. When the measuring current returns to the specified measurement range, the output current will return to normal and the green light will be on.

Instructions

The steps are as follows:

Step 1: Connect the transducer and the control box through a dedicated connection line.

Step 2: Insert the AC 220V power plug into the control box and turn on the power supply switch

Step 3: Pass the current cable to be tested through the transducer and pay attention to the current direction.

Step 4: The current output interface is connected to the current measuring instrument or current sampling circuit. Note that the sampling resistance value cannot exceed the maximum limit value.

Connection System

1. Control box power supply wiring:

The power interface of the control box is directly connected to the 220V power supply;

Red terminal: the positive side of the secondary current output;

Black terminal: the negative side of the secondary current output;

2. Connection of control box and winding coil

Insert the D-Sub9 male connector on the winding coil directly into the D-Sub9 female connector of the control box and fix it with screws.

3. Test description:

By measuring the test current I_s flowing through R_M , or the voltage U_R across R_M ,

The primary current I_P can be obtained:

$$I_P = K_N * I_S = K_N * (U_R / R_M)$$



- High Accuracy
- Broad Bandwidth
- Low Zero-drift

Shenzhen Hangzhi Precision Electronics Co., Ltd.

Product Model: AIT1500-D50
Measurement Range: DC±1500A
Accuracy: 50PPM

Dimensions

Unit: mm

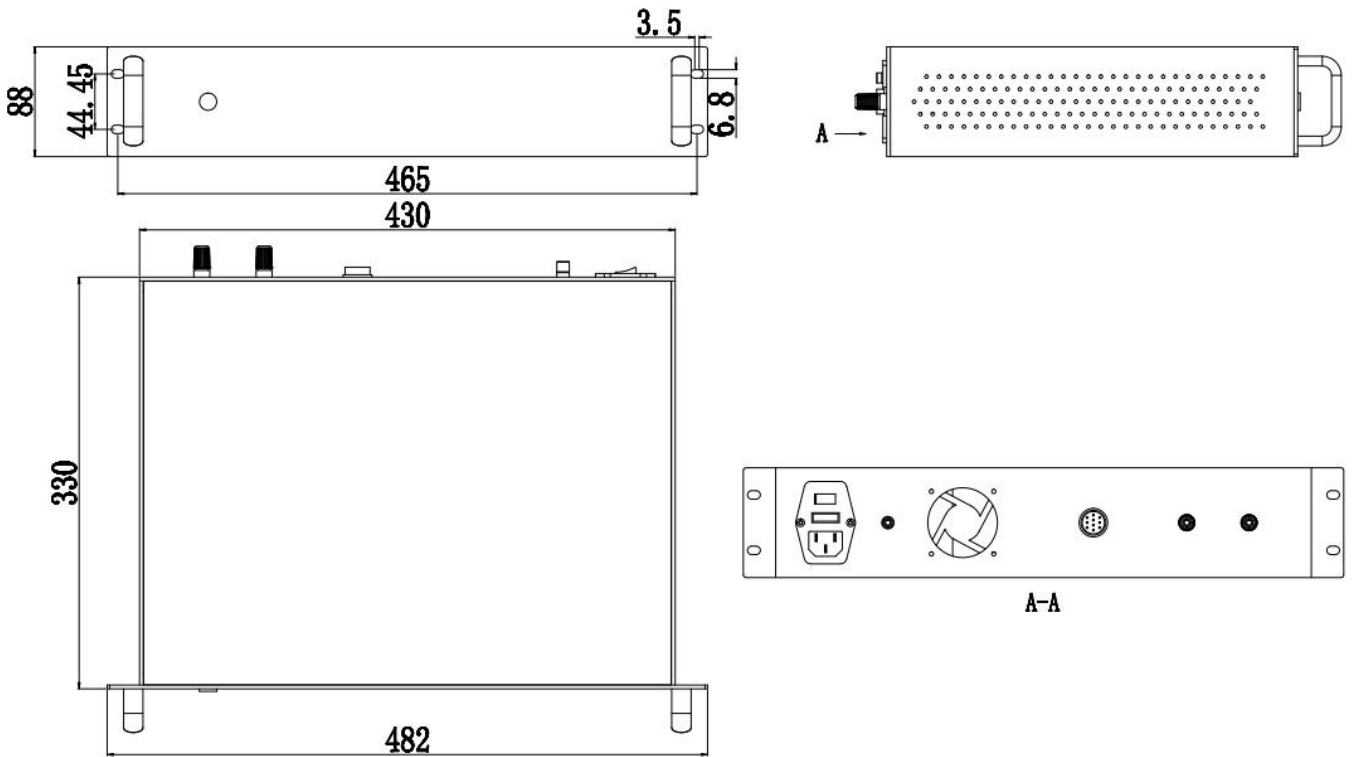

Controller box



- High Accuracy
- Broad Bandwidth
- Low Zero-drift

Shenzhen Hangzhi Precision Electronics Co., Ltd.

Product Model: AIT1500-D50
Measurement Range: DC \pm 1500A
Accuracy: 50PPM

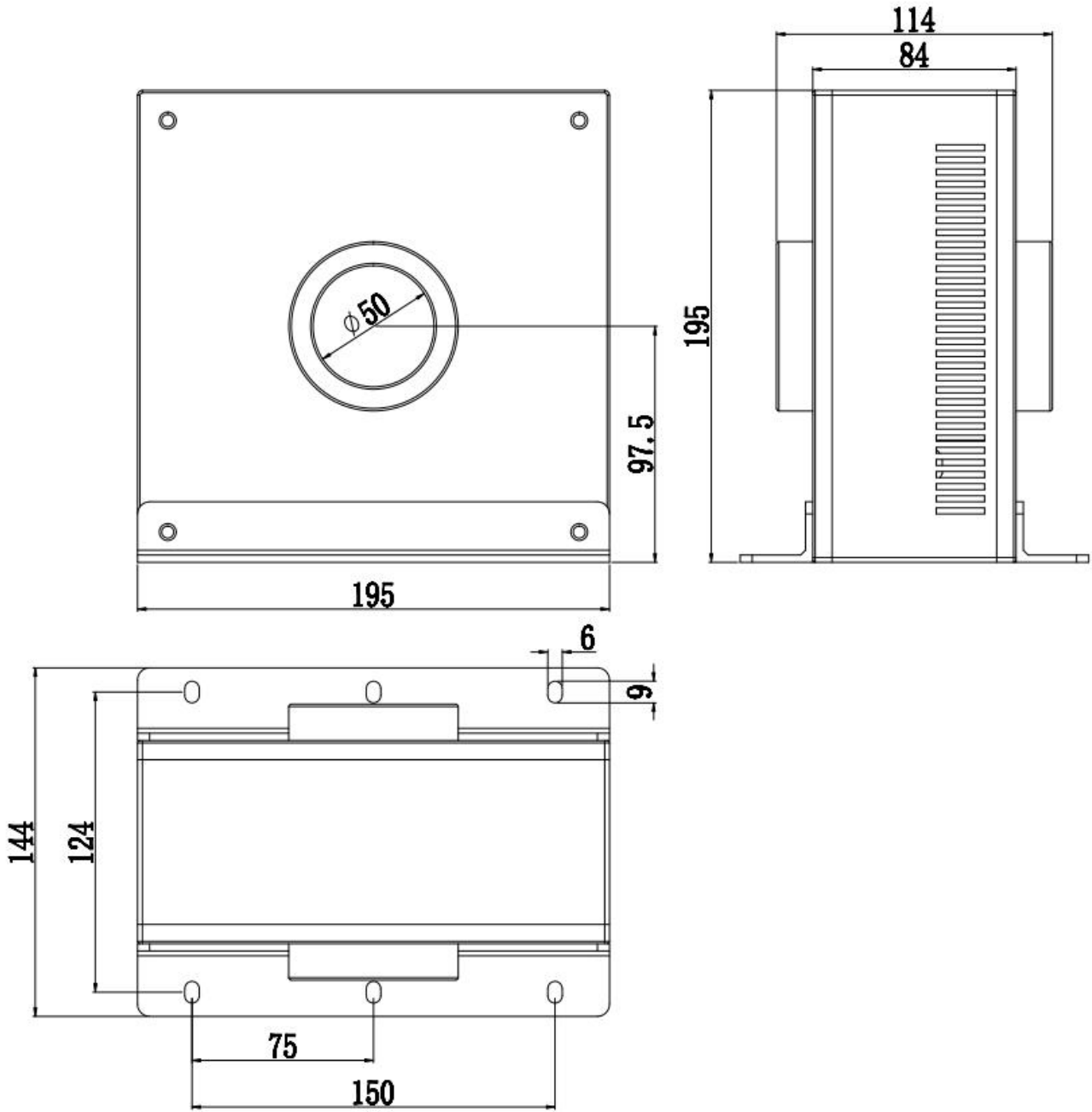

Coil



- High Accuracy
- Broad Bandwidth
- Low Zero-drift

Shenzhen Hangzhi Precision Electronics Co., Ltd.

Product Model: AIT1500-D50
Measurement Range: DC±1500A
Accuracy: 50PPM

Packing List

Item	Description	Quantity	Comments
AIT1500-D50	Controller box	1	/
	Coil	1	/
	AC 220V power supply line	1	/
	Test line	2	One red one black
	Coil connection line	1	/